

## 1. SCOPE

This specification shall be applied to ceramic discriminator for quadrature detection with communication IC.

2. PART NO. : CDBC455C24

## 3. OUTLINE DRAWING AND DIMENSIONS

3.1 Appearance :no visible damage and dirt.

3.2 Dimensions :see Figure 1.

3.3 Construction :to be packaged in synthetic resin and shield with resin the bottom.

## 4. ELECTRICAL CHARACTERISTICS(0°C to +40°C)

### 4.1 Test Method

4.1.1 Input Signal Condition :80dB  $\mu$

4.1.2 Frequency Deviation : $\pm 4.0$ KHz

4.1.3 Modulation Frequency :1.0KHz

### 4.2 Characteristics

	Item	Requirements
4-2-1	Recovered Audio 3dB Bandwidth(from 455KHz)	$\pm 4.0$ KHz min.
4-2-2	Recovered Audio Output Voltage(at 455KHz)	100 $\pm 40$ mV
4-2-3	Distortion(at 455KHz)	2.0% max.
4-2-4	Withstanding Voltage	50V D.C. for 1 minute

## 5. ABSOLUTE MAXIMUM RATINGS

	Item	Requirements
5-1	Withstanding Voltage	50V D.C. for 1 minute
5-2	Insulation Resistance	100M $\Omega$ min. at D.C.100V
5-3	Input Signal Level	5dBm (50 $\Omega$ Termination)
5-4	Operating Temperature Range	-20°C to +80°C
5-5	Storage Temperature Range	-40°C to +85°C

## 6. PHYSICAL AND ENVIRONMENTAL CHARACTERISTICS

### 6.1 Vibration

Discriminator shall be measured after being applied vibration of amplitude to 1.5mm with 600 to 3,300 r.p.m band of vibration frequency to each of 3 perpendicular direction for 24 hours. The measured values shall meet Table 1.

### 6.2 Random Drop

Discriminator shall be measured after 3 times random dropping from the height of 30cm on concrete floor. The measured values shall meet Table 1.

### 6.3 Temperature Characteristics

Discriminator shall be measured within  $-20^{\circ}\text{C}$  to  $+80^{\circ}\text{C}$  temperature range. The measured values shall meet Table 1.

### 6.4 Humidity

After being placed in a chamber within +90 to 95% R.H. at  $+40 \pm 2^{\circ}\text{C}$  for a period of min.100 hours and then being placed in room temperature for 24 hours, the discriminator shall be measured. The measured values shall meet Table 1.

### 6.5 Life Test(High Temp.)

The discriminator shall be measured after being placed in a chamber with  $80^{\circ}\text{C}$  for 100 hours and then being placed in room temperature for min.24 hours. The measured values shall meet Table 1.

### 6.6 Life Test(Low Temp.)

The discriminator shall be measured after being placed in a chamber with  $-20^{\circ}\text{C}$  for 100 hours and then being placed in room temperature for min.24 hours. The measured values shall meet Table 1.

### 6.7 Thermal Shock

After temperature cycle from  $-20^{\circ}\text{C}$  (30 minutes) to  $+85^{\circ}\text{C}$  (30 minutes) was performed 5 times and then being placed in room temperature for min.24 hours. The measured values shall meet Table 1.

Measurements	Requirements
Recovered Audio 3dB Bandwidth(from 455KHz)	$\pm 4.0\text{KHz}$ min.
Recovered Audio Output Voltage(at 455KHz)	$100 \pm 40\text{mV}$
Distortion(at 455KHz)	2.0% max.
Withstanding Voltage	50V D.C. for 1 minute.

Table 1

Figure.1 Dimensions

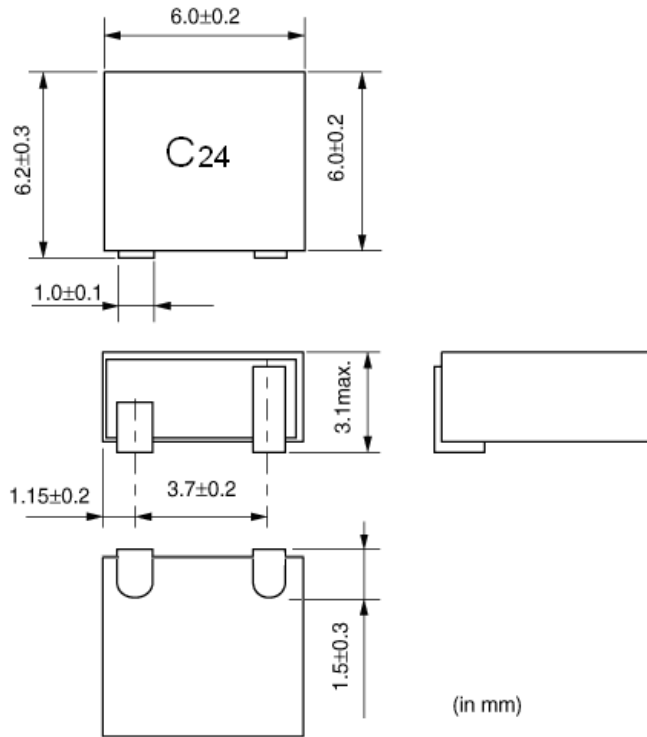
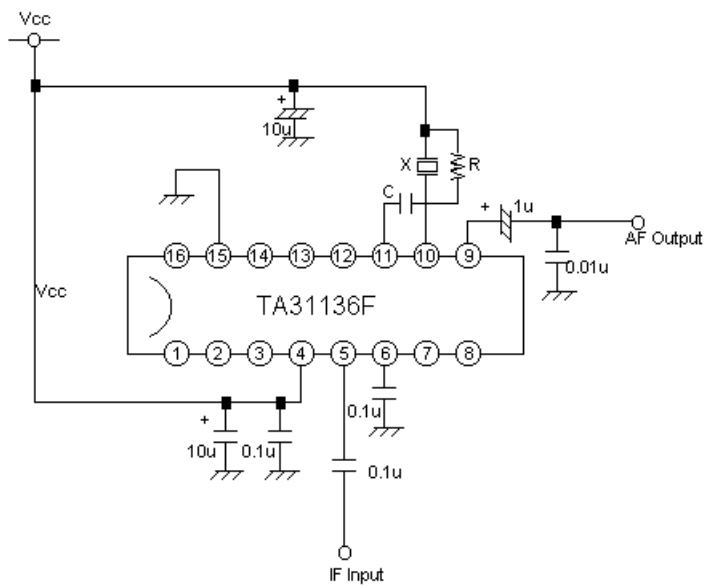

Figure.2

Test circuit for ceramic discriminator



## 7. Notice

- 1) Discriminator might be damaged when an excess stress will be applied.
- 2) This component should be passed through flow soldering and board washing process. Please confirm if the component keeps appropriate characteristics after going through your soldering and washing processes before starting mass production.

Any kind of reflow soldering must not be applied on the component.

- 3) This specification describes about the ability of the component its1f. Please make sure that the component is evaluated and confirmed by mounting onto your products (circuit) before actual use.

## 8. PACKAGE FORM

